

TOTO

SMART TOILET

NEOREST NX-II S Trap

CS903KVT#NW1



FEATURES

- The flagship intelligent toilet of Noster series, with a 360 ° seamless arc design without dead angle, contains healing feeling, radiates vitality and presents an elegant sense of tolerance.
- The toilet cover is coated with special coating, so that the functional part is integrated with ceramics, and the toilet seat is designed with an ergonomic arc to ensure comfortable seating.
- Double-efficient flushing system, water tank flushing plus pipeline direct pressure water flushing, double-effect superposition, forming two strong water flows, effectively reducing water consumption and fully cleaning dirt

SPECIFICATIONS

• Flush System	:	TORNADO FLUSH
• Water Consumption	:	3.0L / 3.8L
• Nominal Water Consumption	:	3.3L
• Water Efficiency	:	Grade 2
• Drainage Mode	:	Underneath Drainage
• Flushing Mode	:	Siphon Jet Water Closet
• Size	:	480W x 800D x 565H
• Power Ratings	:	220~230V, 50/60Hz
• Rough-in	:	305 mm

1.Voltage Stabilizer (1.0 KVA) against to avoid Power Fluctuation.

2.Clean Treated water - Degree of Hardness < 50ppm or TDS < 300 ppm

3.Automatic Water Pressure Pump -Min. Required Pressure - 2.50 Bar (0.25 MPa)

PARTS DESCRIPTION

• CS903KVT#NW1	:	NEOREST NX-II S Trap Bowl with WASHLET (Nickel)
• T53P100	:	Floor Flange

COLOURS

• White (CEFIONTECT)	-	Water closet Bowl
• Nickel	-	Back Center Hinge
	-	Remote Controller

CS903KVT#NW1

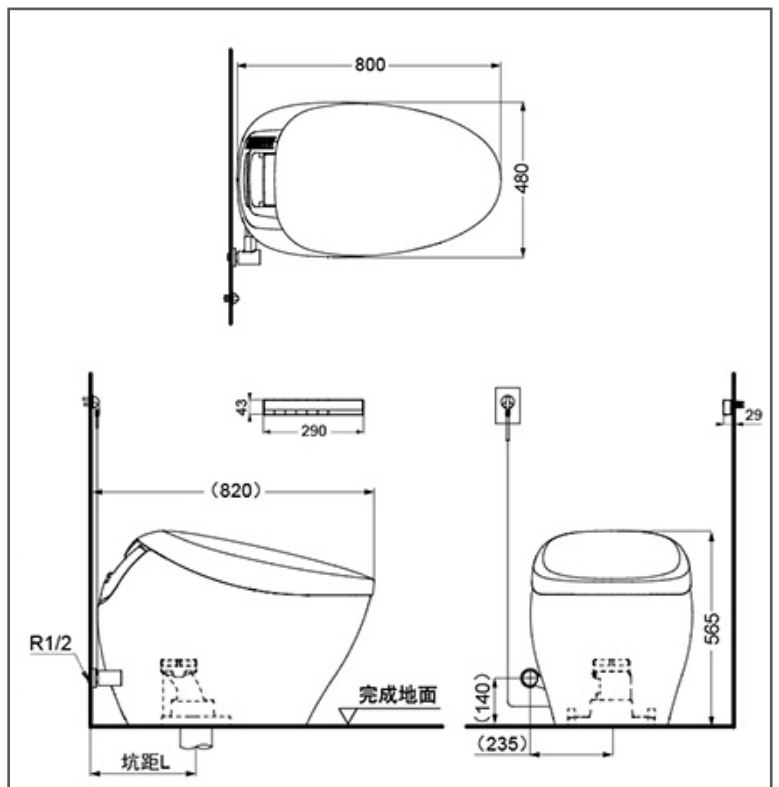

Please consult, TOTO representative for more details.

All rights reserved by TOTO including but not limited to Improve & Change of Product Design, Specs or Availability at any time without prior notice